

1

90939



NEW ZEALAND QUALIFICATIONS AUTHORITY
MANA TOHU MĀTAURANGA O AOTEAROA

SUPERVISOR'S USE ONLY

Level 1 Physics, 2012

90939 Demonstrate understanding of aspects of heat

2.00 pm Monday 26 November 2012
Credits: Four

Achievement	Achievement with Merit	Achievement with Excellence
Demonstrate understanding of aspects of heat.	Demonstrate in-depth understanding of aspects of heat.	Demonstrate comprehensive understanding of aspects of heat.

Check that the National Student Number (NSN) on your admission slip is the same as the number at the top of this page.

You should attempt ALL the questions in this booklet.

Make sure that you have Resource Sheet L1–PHYSR.

In your answers use clear numerical working, words and/or diagrams as required.

Numerical answers should be given with an appropriate SI unit.

If you need more space for any answer, use the page(s) provided at the back of this booklet and clearly number the question.

Check that this booklet has pages 2–12 in the correct order and that none of these pages is blank.

YOU MUST HAND THIS BOOKLET TO THE SUPERVISOR AT THE END OF THE EXAMINATION.

TOTAL

ASSESSOR'S USE ONLY

You are advised to spend 60 minutes answering the questions in this booklet.

QUESTION ONE: HOME HEATING

- (a) On a cold winter morning, water droplets are formed on a window inside a room, as shown in the photograph.

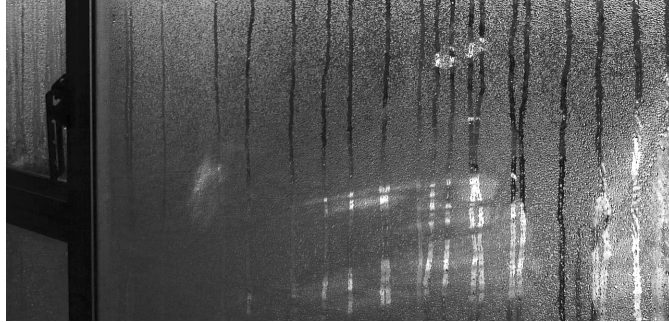

- (i) State the physics term that describes the formation of water droplets on the window.

- (ii) Explain the process by which the water droplets form on the window.

- (b) A room is heated by an electric heater. The room contains 696 kg of dry air at 8.0°C. Specific heat capacity of dry air = 1 006 J kg⁻¹ °C⁻¹.

Calculate the amount of heat energy required to raise the temperature of the **dry air** at 8.0°C to 21°C.

Heat energy _____

- (c) Later in the day when the air in the room becomes humid (moist), each kilogram of air contains 0.020 kg of water vapour. The specific heat capacity of dry air is $1\,006\text{ J kg}^{-1}\text{ }^{\circ}\text{C}^{-1}$ and the specific heat capacity of water is $4\,200\text{ J kg}^{-1}\text{ }^{\circ}\text{C}^{-1}$.

Explain why it takes more heat energy to raise the temperature of 696 kg of humid air by 13°C than it does to raise the temperature of 696 kg of dry air by 13°C .

- (d) A dehumidifier is used to remove water vapour from the air in a room. An electric fan in the dehumidifier forces the air in the room past cold **metal pipes**. The cold metal pipes remove the heat from the water vapour, changing it to liquid water, which is then collected in a container.

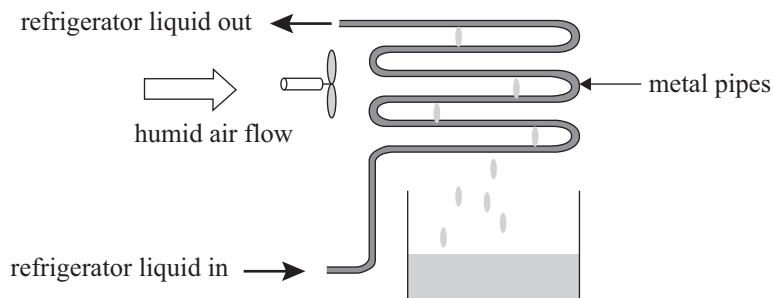

- (i) The pipes contain a liquid refrigerant (refrigerator liquid), which has a low boiling point. When the liquid refrigerant absorbs heat energy from water vapour in the air, it turns into gas.

In the space given below, draw diagrams showing the distribution of particles in the liquid refrigerant and in the refrigerant gas.

liquid refrigerant

refrigerant gas

- (ii) A dehumidifier is run for 6.0 hours. During this period, 12 kg of liquid refrigerant changes into gas in the pipes. The latent heat of vaporisation of the liquid refrigerant is $168\,000\text{ J kg}^{-1}$.

Calculate the amount of heat energy, in kilojoules, required to change 12 kg of liquid refrigerant into gas.

Heat energy _____ kJ

- (iii) During the 6-hour period, 0.95 kg of water vapour in air is converted to liquid water by the dehumidifier. The amount of heat energy given out in this process is $2\,156\,500\text{ J}$.

Explain why the heat energy given out by the humid air is **more than** the heat energy absorbed by the liquid refrigerant.

QUESTION TWO: HOME INSULATION

Without insulation a house will lose heat through the roof, the walls and the floor which will in turn make the house cold. One way of reducing the heat loss through a wooden floor is to cover the area under the floor with aluminium foil.

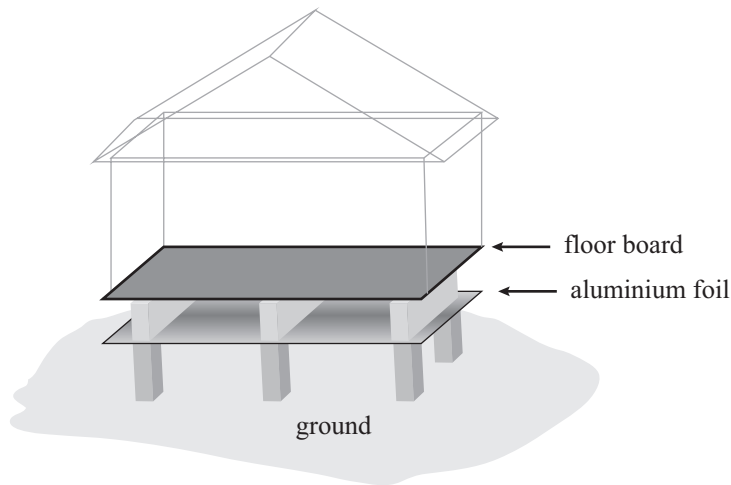

- (a) Explain TWO ways in which the aluminium foil reduces heat loss.

Heat loss through windows can be reduced by double glazing them. Double glazing uses two panes of glass with air between them, and then the sides are sealed airtight.

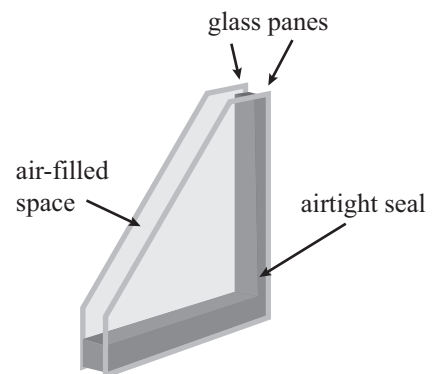

- (b) Explain TWO ways in which double glazing reduces heat loss.

- (c) State a method of reducing heat loss through the walls of the house, and explain how the method you have chosen reduces heat loss.

- (d) The sketch below shows the average heat loss in every two minutes from a house without insulation at 20°C.

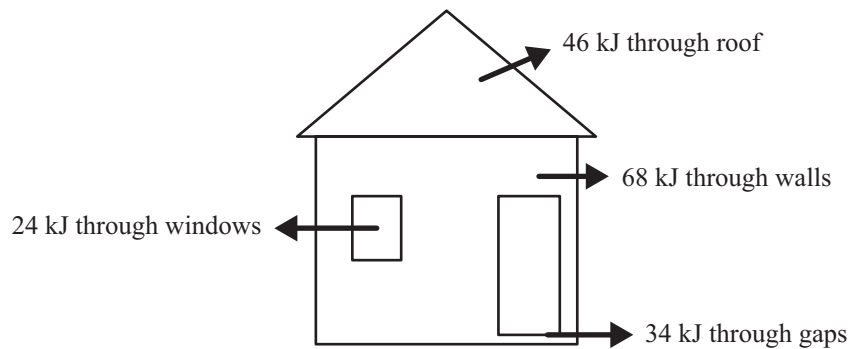

A heater maintains a constant temperature inside the house.

Calculate the power output from the heater to compensate for the heat loss.

Give an appropriate unit with your answer.

Power _____ unit _____

**This page has been deliberately left blank.
The examination continues on the following page.**

QUESTION THREE: CAMPING OUTDOORS

A thermette is a portable device for boiling water in the outdoors. It uses small sticks as fuel. When a fire is lit in the fire chamber at the bottom, the flame moves up the chimney, ensuring efficient heating of water in the jacket that surrounds the chimney.

The thermette is made from copper metal, which has a low specific heat capacity.



ASSESSOR'S
USE ONLY

- (a) Write down the meaning of the term 'specific heat capacity'.

- (b) Explain the advantage of using a metal with a low specific heat capacity to construct a heating device such as a thermette.

- (c) A thermette is made from 1.05 kg of copper. When a fire is lit, 45 885 J of energy is used to change the temperature of the copper part of the thermette from 5.0°C to 120°C.

Calculate the specific heat capacity of copper.

Specific heat capacity _____

- (d) 345 000 J of energy is used to convert some boiling water into steam.

Latent heat of vaporisation of water = $2\,300\,000\text{ J kg}^{-1}$.

- (i) Calculate the mass of the boiling water converted into steam.

Give your answer in grams.

Mass _____ g

- (ii) Both the boiling water and the steam are at the same temperature.

Use the ideas of latent heat of vaporisation and phase change to explain why steam contains more energy than boiling water.

- (e) Even long after the fire has died down, a person who sits near the thermette with hot water in it feels heat from the thermette.

- (i) Name the process for this type of heat transfer.

- (ii) Explain the heat transfer process in (i).

QUESTION FOUR: THE THERMETTE DESIGN

A cross-sectional sketch of a thermette is shown below. It has a fire chamber at the bottom and the chimney in the centre. When the fire is lit in the chamber, the flame rises to the top of the chimney. The water is heated in the water jacket surrounding the chimney.

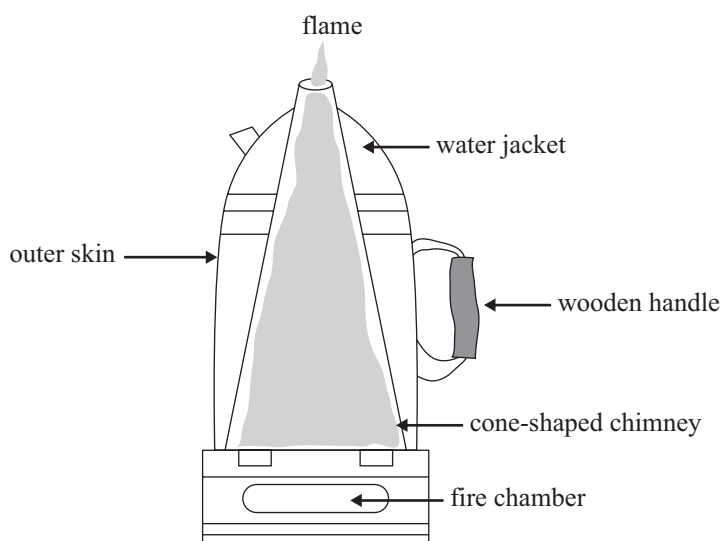

- (a) (i) Name the **main** heat transfer method by which heat energy travels from the chimney to the outer skin of the water jacket.

- (ii) Explain the heat transfer method in (i).

- (b) The handle of the thermette is made of wood.

- (i) State one thermal property of wood that is useful in the design of the thermette.

- (ii) Explain how the design of the thermette makes use of this property.

- (c) Now the water jacket is filled with water and the thermette is heated by lighting a fire in the fire chamber. After a short time, convection currents are set up in the water jacket.

Explain why convection currents occur in the water jacket.

- (d) As shown in the sketch, the chimney is in the centre of the thermette surrounded by the water jacket. The top end of the chimney has a very narrow outlet.

Explain how these design features reduce heat loss by convection and radiation.

